

## 300 Rope Mop Skimmer

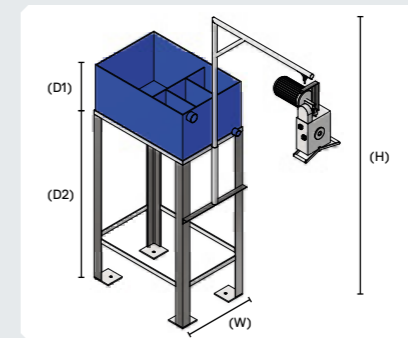

Removes floating oils from separators, sumps, and tanks at a rate up to 300L per hour. Compact, reliable, and easy to operate. Driven by 220v, 380v, 500v or air motors. The oil attracting rope is driven through the skimmer by rubber coated rollers which squeeze the oil via a pipe to the separating tank which ensures water is returned to the separator and only pure oil is recovered. The skimmer recovers mineral, vegetable, and animal oils.



### TECHNICAL SPECIFICATIONS

Oil Recovery	Up to 300L/HR
Roper Diameter	150mm
Max Rope Length	80m
Motor Power	40m
Motor RPM	0.37KW
Rope Speed	1440RPM
Guide Pulley	FPG 300
Drive Options	Electric, Air
Weight Incl. Motor	30kg
Height (H)	1812mm
Depth (D1)	304mm
Depth (D2)	1006mm
Width (W)	425mm

### CODE DESCRIPTION

EP30220	DRIZIT 300 Oil Skimmer 220V
EP30380	DRIZIT 300 Oil Skimmer 380V
EP30525	DRIZIT 300 Oil Skimmer 525V
EP30221	DRIZIT 300 Oil Skimmer - 200V Flameproof C1,D1,GD
EP30381	DRIZIT 300 Oil Skimmer - 380V/525W Flameproof C1, D1, GD
EP30800	DRIZIT 300 Oil Skimmer Air Driven With Filter Lubricator
EP30350	TS 300 Separating Tank
EP30300	ST 300 Stand
EP30360	Oil Outlet Hose C/W Rite Fittings



## 850 Rope Mop Skimmer

Uses the same principle as the 300 Skimmer but has a maximum recovery rate of 1000L/hr and is fitted on top of an integrated oil/water separating tank. Being more powerful than the 300, it can skim larger areas using floating guide pulleys to effectively cover the required areas. Boreholes up to 25m deep can also be cleared.

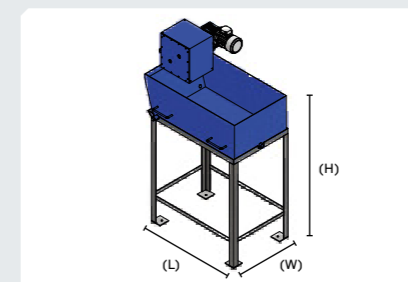

### TECHNICAL SPECIFICATIONS

Oil Recovery	Up to 1000L/HR
Roper Diameter	150mm
Max Rope Length	120m
Max Lift	45m
Motor Power	0.37KW
Motor RPM	1440RPM
Rope Speed	18m/min
Guide Pulley	FPG 300
Drive Options	Diesel, Electric, Air
Weight Incl. Motor	80kg
Height (H)	1445mm
Length (L)	965mm
Width (W)	640mm

### CODE DESCRIPTION

EP80220	DRIZIT 850 Oil Skimmer	220V Weatherproof
EP80380	DRIZIT 850 Oil Skimmer	380V Weatherproof
EP80525	DRIZIT 850 Oil Skimmer	525V Weatherproof
EP80221	DRIZIT 850 Oil Skimmer	220V Flameproof C1, D1, GD
EP80381	DRIZIT 850 Oil Skimmer	380V/525W Flameproof C1, D1, GD
EP80800	DRIZIT 850 Oil Skimmer	Air Driven C/W Filter Lubricator
EP80900	DRIZIT 850 Oil Skimmer	Yanmar Diesel
EP80350	TS850 Separating Tank	Separating Tank
EP80300	ST850 Stand	Stand

